

Concept 500

Self Adhesive Label Applicator.



- Operates at speeds up to 250/min.
- Freestanding or conveyor-mounted.
- Quick release fittings for fast label changeover.
- Robust construction for arduous environments.
- Servo motor label drive.



Labelling systems for the most demanding applications

The AEW Delford Concept 500 self-adhesive label applicator is designed for integration into packaging lines where production speeds and reliability are of paramount importance. This high performance applicator offers labelling for the most demanding applications.

The **Concept 500** can be supplied as a free-standing unit for portability, or it can be mounted on a purpose-built conveyor as an over or under system.

For base labelling the applicator is incorporated into a purpose-built split conveyor.

Where there is a requirement to use stock reels that have labels in the incorrect orientation for the way they are to be positioned on the pack, the unit can be supplied with an optional rotation and blow down kit.

For applying a label to more than one surface of a pack, the **Concept 500** can be mounted on a purpose-built conveyor that incorporates a top and bottom label application system to ensure high accuracy.

Should there be a requirement for printing on such a label, a thermal transfer printer can be incorporated.

A powerful servo-motor driven label feed ensures high accuracy placement at speeds up to 250/min and a robust stainless steel construction makes it suitable for the most arduous environments.

A comprehensive, user-friendly control module makes the **Concept 500** easy to set up for label and coder controls. The easily accessible, quick release fittings also enable the label reel to be changed with the minimum of delay.

Integrated Systems

The **Concept 500** self-adhesive label applicator can operate as a stand alone machine or it can be integrated with a range of manual or automatic production lines.



The comprehensive, user-friendly control module enables the operator to easily set conveyor speeds and label positions. Information can be entered on the screen and, when running, the system operates in a diagnostic mode.



Free-standing system with Concept A500 applicator.



Labeling applications

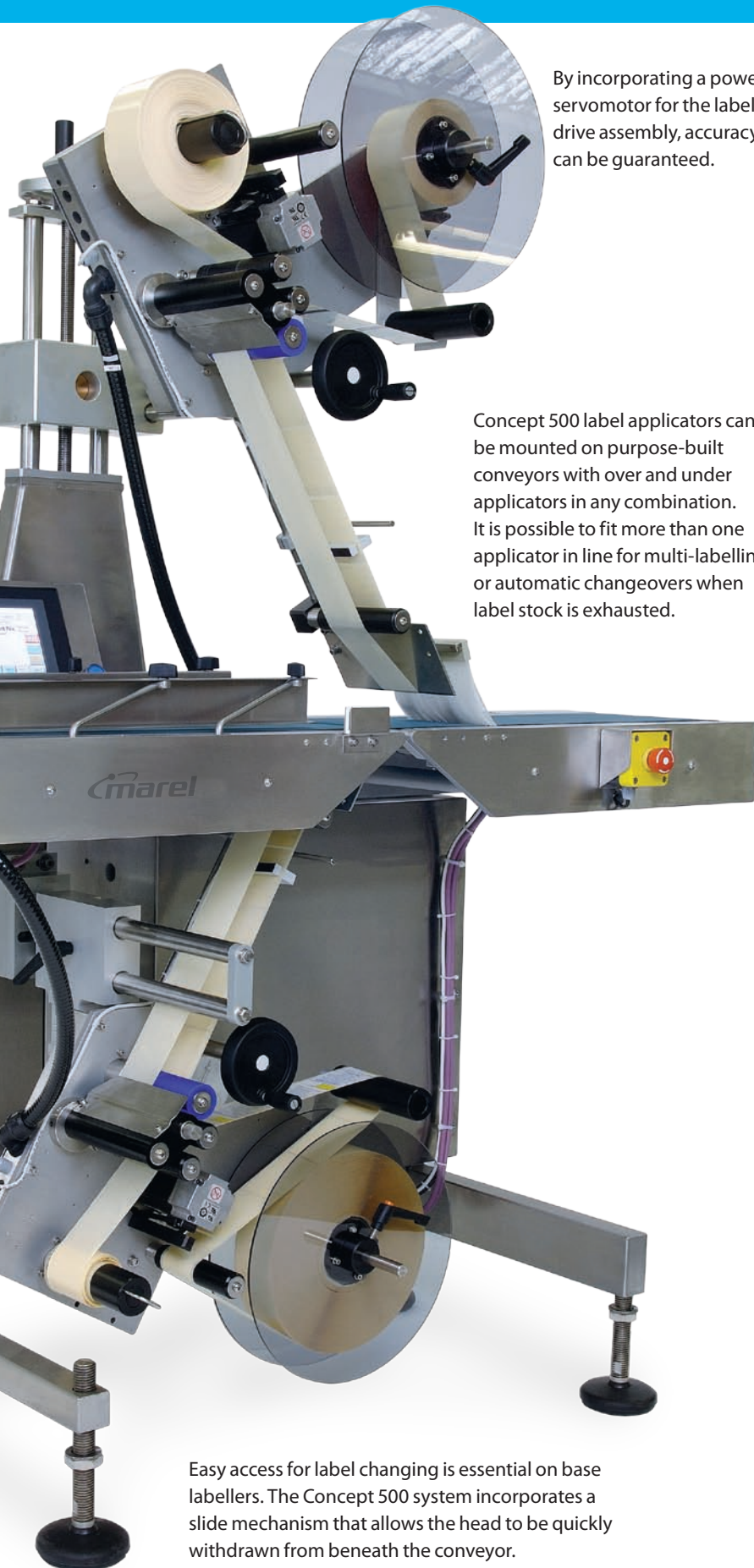

By incorporating a powerful servomotor for the label drive assembly, accuracy can be guaranteed.

Concept 500 label applicators can be mounted on purpose-built conveyors with over and under applicators in any combination. It is possible to fit more than one applicator in line for multi-labelling or automatic changeovers when label stock is exhausted.

Easy access for label changing is essential on base labellers. The Concept 500 system incorporates a slide mechanism that allows the head to be quickly withdrawn from beneath the conveyor.



Concept A500 Label Applicator

By replacing the standard applicator beak with an air blast assembly, the unit can apply labels in any direction on the pack by means of a rotating, lockable mounting. This can be supplied as a stand alone system for mounting over an existing conveyor, or it can be fitted to a purpose-built conveyor.

Concept C3 Panel Label Applicator

When the Concept 500 applicator is vertically mounted over a split belt conveyor, the system is capable of positioning a label around three sides of a tray or container.

The AEW Delford Concept C3 Panel Label Applicator grips the pack on driven side belts and suspends the label, allowing the pack to be driven through it. Where printing is a requirement, the unit can be fitted to the C3, which can print variable or fixed information.

For ultimate flexibility an AEW Delford integral weighing system can be interfaced upstream whereby all packs are weighed and the information forwarded to the Concept C3 Panel label applicator.



Concept 500 Label Applicator

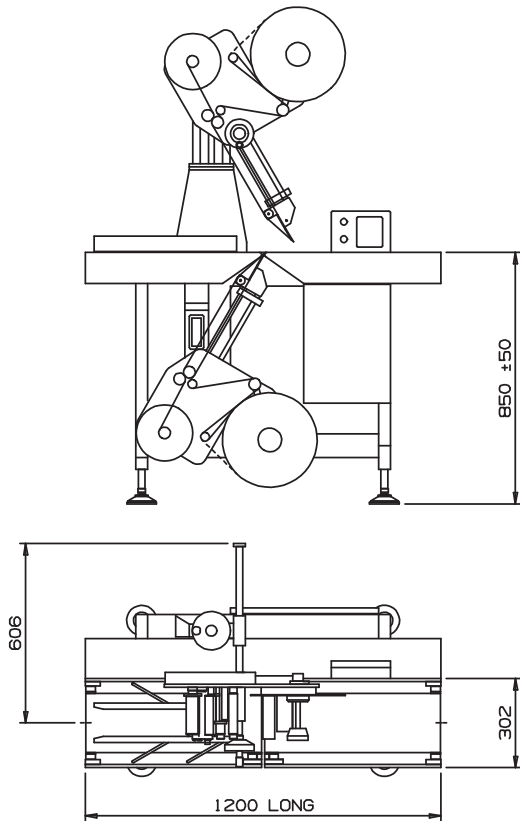

Technical Information

Label size: up to 125mm

Optional label sizes: Up to 160mm and 210mm

Labelling speed: Up to 60m/min

Electrical supply: 110/240V Single phase 50/60 Hz

Label reel: 300mm diameter

Label reel core size: 76mm or 38mm

Air required where applicable: 6.5 l/min at 6 bar

Max. conveyor speed where applicable: 0.8m/sec

Options

- Nodding beak, solenoid or air driven for consistent labelling accuracy.
- Hot foil coder for printed information.
- Low reel detection alarm.
- Intelligent variable over-printer with over 100 programs.
- Floor-mounted stainless steel stand.
- Can be interfaced to a Weigh Price Labeller for selective labelling.
- Variable speed control.

Marel

The leading global provider of advanced equipment and systems for the fish, meat and poultry industries.

Marel, Stork Poultry Processing and Townsend Further Processing – Our brands are among the most respected in the fish, meat and poultry processing industries. Together, we offer the convenience of a single source to meet our customers' every need.

For further information please visit

www.marel.com / www.storkpoultry.com