

I-Slice 1068 VA

For intelligent slicing of meat

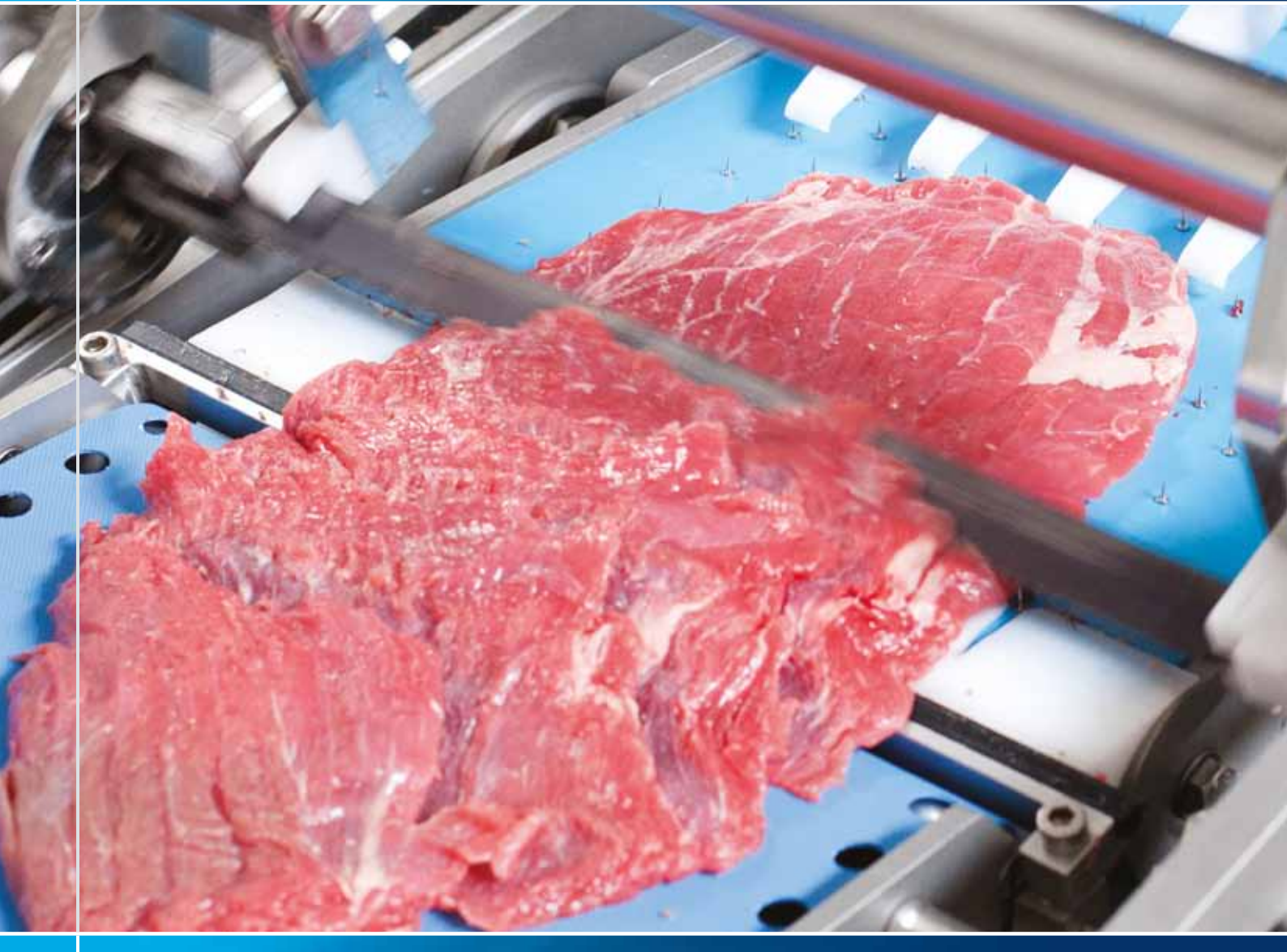

- Fixed weight, high accuracy
- Increases yield, throughput and quality
- Flexible cutting angle 10°- 68°
- Labour costs savings
- Easy to operate



Exceptional meat slicing

Fixed weight · yield optimized · fixed angle and thickness

I-Slice 1068 VA

Using the latest in vision technology, the I-Slice 1068 VA scans each piece of raw meat before slicing, and then calculates the most efficient cut configuration based on weight and shape.

This makes the machine capable of making fixed weight cuts. During slicing either the slice length or the slice thickness is automatically adjusted to hit the target weight, depending on the predefined programme. This optimises production value and ensures correct weight on each slice of meat.

The I-Slice 1068 VA can cut various types of meat into portions or escalopes. The wide cutting angle range makes it possible to cut the meat in both low and high angle, creating “plate filler” pieces with great surface and low weight. The giveaway is reduced to an absolute minimum, and the costs for labour and training will be reduced significantly compared to manual production.

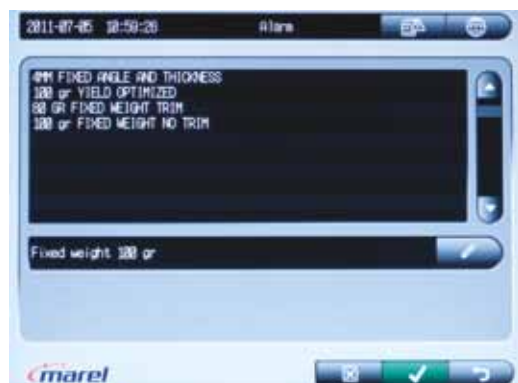

Three efficient cutting modes

1) Fixed weight

The machine calculates and cuts the meat according to target weight, producing as many pieces with the defined weight as possible.

2) Yield optimized

The calculation is done with the aim of using all of the meat. The cutting is done within the specified minimum and maximum weight.

3) Fixed angle and thickness

The meat is cut with fixed slice thickness and slice angle, with variable weight on the end product.

For option 1 and 2 a trim cut can be programmed to achieve maximum accuracy. All 3 modes includes a programming facility to space out the portions. This function will depend on slice angle and portion length.

Easy and safe operation

The slicer is operated by a colour touch screen with a user interface, which makes the operation of the slicer easy and safe for employees at all levels. The cutting calculation for each piece of meat, can be monitored on the screen prior to cutting.

Solutions

Various complete solutions with packing line and check weighing are available, including two-way line control that synchronizes the speed of the slicer and the packing line.

Benefits

- High quality output with fixed weight end products
- The optimum processing results in increased yield and throughput
- Labour costs will be reduced because of the automated process
- Useful for multiple products within a wide cutting angle range
- With the user-friendly touch screen operation is made easy and safe

High flexibility

Wide cutting angle range

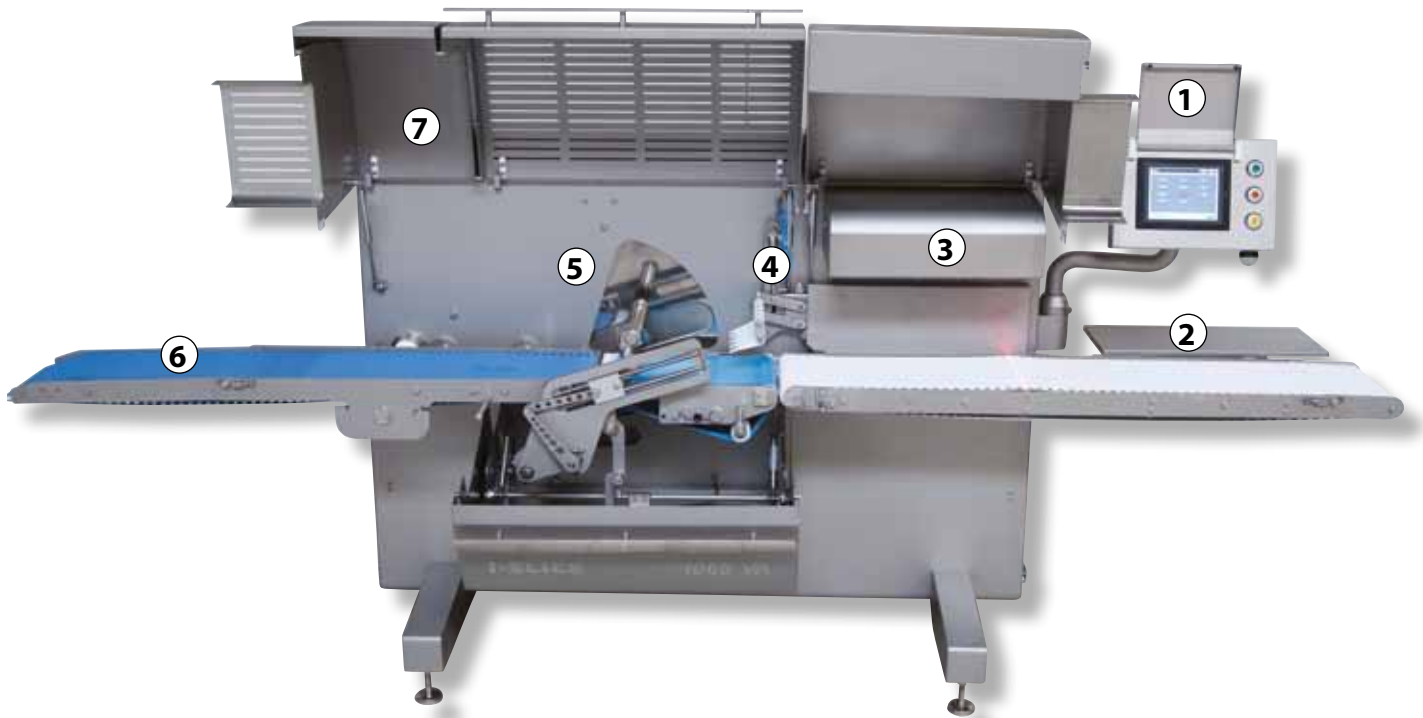

1) **Touch screen;** easy and safe to operate

2) **Scale;** for density calibration

3) **Vision scanning unit;** the laser scans each piece of meat before slicing to calculate the optimum slicing

4) **Product fixation;** to secure that the product is stable and fixed to the conveyor belt during cutting

5) **Cutting section;** the knife automatically changes its cutting angle in order to cut each slice with the correct weight

6) **Quick release belt;** conveyor belts are easy to remove for inspection and cleaning with no tools required

7) **Hygienic design;** the design of the machine ensures easy access for cleaning and maintenance



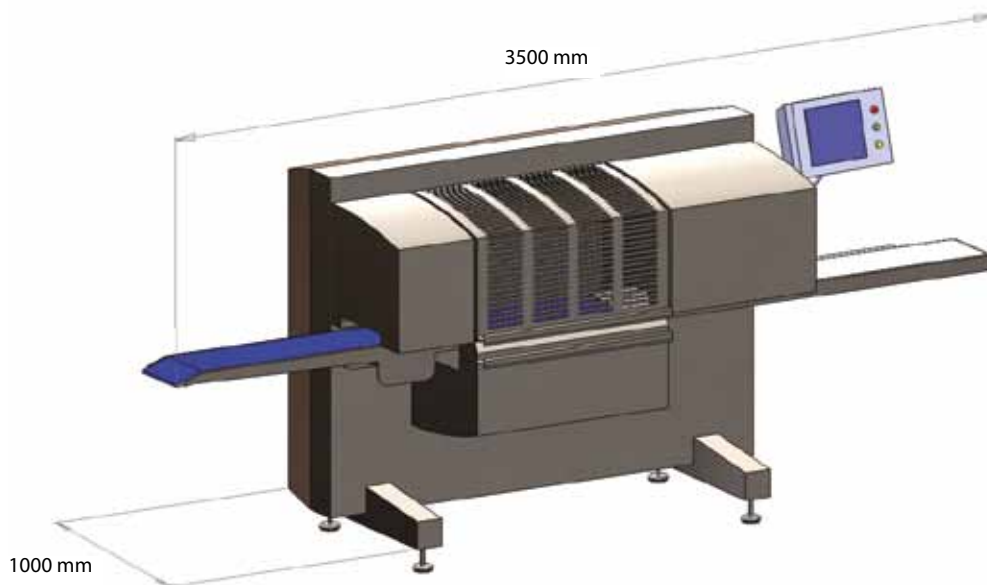

Capacity:	Up to 300 kg/hour *	Electricity:	3x400V + N + PE / 3x220V + PE
Knife speed:	Up to 125 cuts/min. *	Power consumption:	1,6 kW
Cutting angle:	10°-68°	Weight:	700 kg
Max. product height:	80 mm	Dimensions L x W x H:	3500 x 1000 x 1485 mm
Slice thickness:	From 3 mm	Product temperature:	0° C to + 4° C
Max. cutting width:	250 mm	Compressed air:	10 l/min, min. 6 bar pressure, 6 g water per Nm ³ air, max. particle size up to 40 µm

* Depending on product specification

The machine is designed in accordance with CE standards



Marel

The leading global provider of advanced equipment and systems for the fish, meat and poultry industries.

Marel, Stork Poultry Processing and Townsend Further Processing – Our brands are among the most respected in the fish, meat and poultry processing industries. Together, we offer the convenience of a single source to meet our customers' every need.

For further information please visit

www.marel.com