

Superflow Easyclean Freezer Twin Belt - Dual Impingement

Type: Dantech FT/SFEC/TB/DI 1000 - 1500 Series

FREEZING & TEMPERATURE DIVISION



- Fully factory assembled
- Extremely flexible
- Easyclean system
- Energy efficient
- Compact unit

Type: Dantech FT/SFEC/TB/DI 1000 - 1500 Series

The Superflow Easyclean® Tunnel Freezer is specially designed for freezing of Small Products, Shrimps, Fish Fillets, Hamburgers etc, fragile products, and products placed on trays.

The freezer arrives fully factory assembled at site and requires minimum amount of time for installation. The freezer is supplied with electrical hoist motors to lift the fully welded stainless steel insulated top cover for easy cleaning and maintenance. Furthermore, compared to other freezing systems, the freezer does not require a concrete foundation or any other foundations.

With a simple change in air plates, the freezer is easily adaptable for both high speed vertical airflow, called Superflow® and a conventional high speed horizontal airflow, called Arcticflow®. This will provide the user great flexibility to minimize the cost of freezing. However the capacity will vary depending on the type of airflow, product loads etc.

Further the air guidance plates are stepless adjustable to optimize the freezing times and energy usage.

Both the Superflow® and the Arcticflow® airflow together with the ultra low temperature ensure a quick and homogenous freezing within a minimum of time. Thus ensuring a good quality finished product, with an equalised core temperature of min. -18°C.

The machine is equipped with programs for energy savings purposes.



Open Design for Easy Cleaning



Hoistable Cover for Easy Access & Cleaning



Factory Assembled to fit a 40' Container

SUPERFLOW EASYCLEAN TWIN BELT DUAL IMPINGEMENT

Type: Dantech FT/SFEC/TB/DI 1000 - 1500 Series

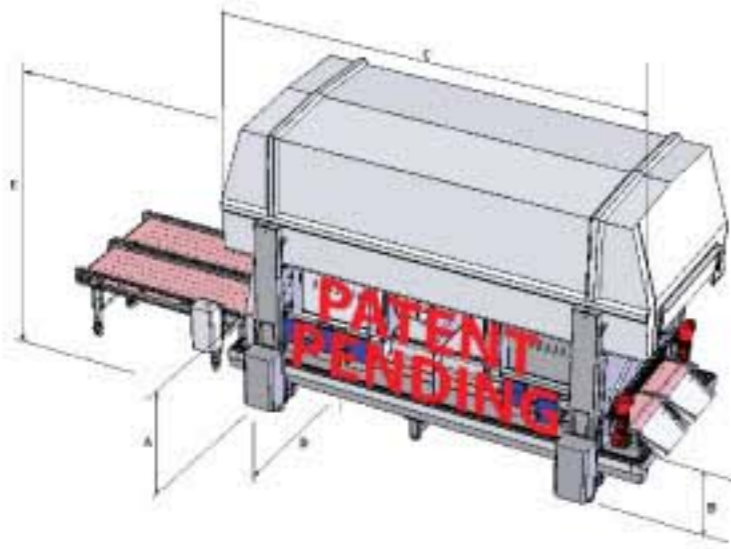

- Compact Unit
- Fully Factory Assembled
- Easyclean System
- Great Flexibility
- Energy Saving
- Fast Installation

The Superflow Easyclean Freezers are available in solutions ranging from 2 - 12 modules in both belt widths

Superflow Easyclean Freezer Twin Belt - Dual Impingement	FT/SFEC TB/DI/1000/2/46	FT/SFEC TB/DI/1000/4/92	FT/SFEC TB/DI/1000/6/138	FT/SFEC TB/DI/1000/12/276	FT/SFEC TB/DI/1500/2/70	FT/SFEC TB/DI/1500/4/140	FT/SFEC TB/DI/1500/6/210	FT/SFEC TB/DI/1500/12/420
TECHNICAL DATA :								
No. Of Modules	2	4	6	12	2	4	6	12
Belt Width (Effective) (mm):	450	450	450	450	700	700	700	700
Belt Width (Overall) (mm):	500	500	500	500	750	750	750	750
Belt Length (mm):	5070	9390	13710	26670	5070	9390	13710	26670
No. of belt :	2	2	2	2	2	2	2	2
Belt Speed (*) (m/min):	Adjustable	Adjustable	Adjustable	Adjustable	Adjustable	Adjustable	Adjustable	Adjustable
Product Height (Normal) (NP) (mm):	0 ~ 125	0 ~ 125	0 ~ 125	0 ~ 125	0 ~ 125	0 ~ 125	0 ~ 125	0 ~ 125
Product Height (High version) (HP) (mm):	125 ~ 225	125~225	125~225	125~225	125~225	125~225	125~225	125~225
Product Infeed Height (A) (mm):	850	850	850	850	850	850	850	850
Product Discharge Height (B) (mm):	595	595	595	595	595	595	595	595
Max. Length (C) (mm):	5420	9740	14060	27020	5420	9740	14060	27020
Max. Width (D) (mm):	2450	2450	2450	2450	2950	2950	2950	2950
Max Height (Hood Up) (E-NP) (mm):	3565	3565	3565	3565	3565	3565	3565	3565
Max Height (Hood Up) (E-HP) (mm):	3765	3765	3765	3765	3765	3765	3765	3765
Max Height (Hood Down) (F-NP) (mm):	2590	2590	2590	2590	2590	2590	2590	2590
Max Height (Hood Down) (F-HP) (mm):	2690	2690	2690	2690	2690	2690	2690	2690
Coolant Supply to Evaporator (*) (KW):	Varies	Varies	Varies	Varies	Varies	Varies	Varies	Varies
Max Evaporator Available (KW):	46	92	138	276	70	140	210	420
Suction Temp at Evaporator (°C):	-40	-40	-40	-40	-40	-40	-40	-40
Air Temperature (°C):	-35	-35	-35	-35	-35	-35	-35	-35
Cooling Medium :	R404A/R717/R22	R404A/R717/R22	R404A/R717/R22	R404A/R717/R22	R404A/R717/R22	R404A/R717/R22	R404A/R717/R22	R404A/R717/R22
Cooling Pump Flow Rate :	4 to 5 times	4 to 5 times	4 to 5 times	4 to 5 times	4 to 5 times	4 to 5 times	4 to 5 times	4 to 5 times
Total Power Consumption (Max) (*) (KW):	12	24	36	72	16	32	48	96
Installed Fan Power (KW):	18.4	36.8	55.2	110.4	18.4	36.8	55.2	110.4
Power Supply (KW):	22	40	58	114	22	40	58	114
Voltage (V):	3 x 400/50Hz	3 x 400 / 50Hz	3 x 400 / 50Hz	3 x 400 / 50Hz	3 x 400 / 50Hz	3 x 400 / 50Hz	3 x 400 / 50Hz	3 x 400 / 50Hz

Design:

- Cabinet : 125mm fully welded Stainless Steel Panels
- Conveyor : Stainless Steel Conveyor Frame & Belts
- Optional : Pre fabricated PU Panel Stainless Steel Surface or White PVC

PLC/Touch Screen Control Panel :

- Stepless control of belt speed
- Digital read out of freezing time
- Digital read out of air and evaporating temperature
- Digital control of stepless adjustments of plates
- Start/stop of belt
- On/off switch for light in tunnel

All above mentioned details are subject to change without notice !

(*) These parameters will be different depending on the Geometrical and Thermal Characteristic of Product

Different Belt Types for a Easyclean Tunnel Freezers



DTZ Belt

Stainless Steel Mesh Belt

DTZ Flat Modular Stainless Steel Belt

Plastic Modular Belt

Worldwide Service



Marel Australia
Unit 1,
53 Neumann Road
Capalaba Qld 4157
Australia
Tel: +61 7 3395 8044

Marel France
60 Avenue Paul Cezanne
BP 295
VANNES Cedex 56008
France
Tel: +33 (0) 2 97 46 49 46

Marel New Zealand
27c Kennaway Road
Woolston
Christchurch 8023
New Zealand
Tel: +64 3 381 8100

Marel Slovakia
Novozamocka 222
Nitra
Slovakia 949 05
Tel: +421 37 6530 741

Marel U.K. (Leicester)
Feldspar Close
The Warrens Ind. Park
Enderby Leicester
LE19 4JS
United Kingdom
Tel: +44 (0) 116 284 3500

Marel Brazil
Rua Jose Tomasi, nº 634
Santa Felicidade
Curitiba, PR
82.015-630
Brazil
Tel: +55 41 3888 3400

Marel Germany
Hakenbusch 9
Osnabruck D-49078
Germany
Tel: +49 (0) 541 500 97-0

Marel Norway
Karvag
Averøy 6530
Norway
Tel: +47 715 17300

Marel (Pty) Ltd South Africa
1st Floor, Fish Eagle Park 2
Loerie Street, Meyersdal
1447 Gauteng
South Africa
Tel: +421 37 6530 741

Marel Uruguay
Ramon Mansini, 3134
Montevideo 11300
Uruguay
Tel: +598 2 707 6230

Marel Chile
Bernardino 1057, Modulo 1
Flex Center, Loteo Industrial
San Andres, Puerto Montt,
Chile
Tel: +56 65 341 818

Marel Iceland
Austurhraun 9
210 Gardabaer
Iceland
Tel: +354 563 8000

Marel Poland
ul. Oplotek 29
Warszawa 01-940
Poland
Tel: +48 22 569 52 80

Marel Spain
C/Copernic, 2-4 Nave 1
Pol. Ind. Cami Ral
Gava Barcelona 08850
Espana
Tel: +34 936 36 35 93

Marel USA (Kansas)
8145 Flint Street
Lenexa KS 66214
United States of America
Tel: +1 913 888 9110

Marel China
No. 36 Hong Kong Mid Road
Room 1108
Zhao Yin Tower of Cyber Port
Qingdao 266071
China
Tel: +86 532 8667 5567

Marel Ireland
Unit B2
Centrepont Business Park
Dublin 12 Clondalkin
Oak Drive 12
Ireland
Tel: +353 142 982 06

Marel Portugal
Centro Empresarial "Lusoworld"
2710-335 Linho
Sintra Armazem 6 Rua Pe de Mouro
Portugal
Tel: +351 21 9241393

Marel Sweden
Norra Långebergsgaten 4
Göteborg 400 92
Sweden
Tel: +46 31 709 0707

Marel USA (Seattle)
2001 West Garfield
Terminal 91, Pier 91, Building A-1
Seattle, WA 98119
United States of America
Tel: +1 206 781 1827

Marel Denmark
P.O. Pedersens Vej 18
DK - 8200 Aarhus N
Denmark
Tel: +45 89 304 444

Marel Italy
Via Leonardo da Vinci 9
San Rocco al Porto
Lombardy 26865
Italy
Tel: +39 0377 456065

Marel Romania
Tudor Stefan Street no.13
011655 Bucharest
Romania
Tel: +4 0314 253 114

Marel Thailand
2nd Fl., Ratchaphurk Bldg.
Bangkunkong, Bangkruai
Nonthaburi 11130
125/4 Moo 1, Ratchaphurk Road
Thailand
Tel: +66 2423 3656-9

Marel Vietnam
80 Nguyen Dinh Chieu Street
Ho Chi Minh City Q1
Vietnam
Tel: +84 (8827) 4462

Marel Salmon A/S
Bøgildsmindevej 3
9400 Nørresundby
Denmark
Tel: (45) 9892 1511

Marel Netherlands
Hogerwerf 18
Roosendaal
4704 RV
The Netherlands
Tel: +31 0165 523030

Marel Russia
Proezd No.607, bld.30
Office 602
Moscow 123458
Russia
Tel: +7 (495) 228 0550